

ASSEMBLY, INSTALLATION & OPERATING INSTRUCTIONS

SERIES ARV AIR RELEASE VALVES

1. IMPORTANT – BEFORE INSTALLATION

Air Release Valves will vent gases for a liquid-carrying pipeline or vessel at system start-up. A hollow poppet floats on the liquid surface while gas is being vented then, when the poppet floats to the seat, the valve closes and remains closed until pressure and liquid are removed from the valve (ie. system draining). The specific gravity of liquid shall not be less than 0.9.

Caution: Plastic materials will degrade in ultra-violet (UV) light or sunlight.

2. INSTALLATION

The air release valve should be installed in an upright position at the highest point in the piping system or vessel. In most cases, residual liquid and/or vapor in the valve may be released from the outlet port just prior to valve shut-off therefore, Plast-O-Matic recommends piping the outlet port to a safe area or use of a standpipe for non-hazardous liquids.

Threaded Connections – A suitable thread sealant (ex. Teflon® tape) should be applied to male tapered threads to assure a “leak-tight” seal. The assembly need only be made “hand-tight” followed by a quarter (1/4) turn with a strap wrench. Do not over tighten or use pipe wrenches on plastic pipe and components.



Caution: Teflon tape will “string” as pipe threads are joined. Loose “strings” could lay across the seating surface and prevent the valve from completely closing. To avoid this problem, clean out the old tape, and do not apply tape to the first thread.

Caution: Connection should be made only to plastic fittings; metal pipe should only be installed with an intervening plastic nipple. Metal pipe and straight threaded pipe tend to cut, stretch, or distort the plastic bodies, which could result in cracking or leaking over time.

3. MAINTENANCE

Plast-O-Matic recommends keeping a spare seat and O-ring set available for repairs. Seal life will vary in applications due to cycles, temperatures, pressures, chemicals, and concentration. Based on the application, a periodic inspection and maintenance plan should be established.

4. PARTS AND ILLUSTRATION

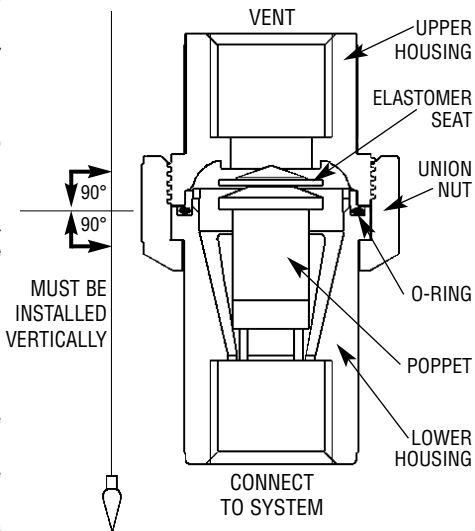

Plast-O-Matic Valves, Inc.

1384 Pompton Avenue, Cedar Grove, New Jersey 07009
(973) 256-3000 • Fax: (973) 256-4745 • www.plastomatic.com

09/04