

Temperature Sensors with Connectors



LIMATHERM SENSOR Sp. z o.o.

34-600 Limanowa, Tarnowska 1, tel. (+48 18) 330 10 06, fax: (+48 18) 330 10 04

NIP: 737 19 66 189, REGON: 492926443

www.limathermsensor.com, e-mail: export@limathermsensor.pl



Temperature Sensors with Connectors

The following Operation Manual provides information of temperature sensors:

- with Hirshmann GSP connector: TO..GSP-1, APTO..GSP-1
 - with Hirshmann M12 connector: TO..G-M12, APTO..G-M12, TO..I-M12, APTO..I-M12, TOP-MA12,
 - with LEMO connector: TOPGL-1082, PTOB-BTL
- and sensors with different construction or with different connectors, acc. to client requirements.

Temperature sensors are manufactured in compliance with PN-EN 60751

1. Construction and principle of operation.

The basic element of the temperature sensor is resistor extended with stranded copper wire. The sensing element is placed in steel thermowell of acid-resistant or different specified material (brass, aluminium, PTFE, etc.). The thermowell is terminated with a plug with connectors, that can be joined with the adequate straight or angular socket, mounted on the cable used for connection with other devices (e.g. controllers, transmitters). This connection can be made with 2-, 3- or 4-wire configuration. Both elements of a plug connector can be joined by screw (GSP) or twisted (M12) for ensuring the leak tightness of connection.

Various connectors or threaded nuts are used for sensor mounting, for example joined to the thermowell or moveable (that press the ring joined with the thermowell) or enabling the modification of sensor immersion length.

Sensing element reacts to temperature changes through the change of resistance. These changes are compatible with characteristics of thermometric resistors provided in suitable norms.

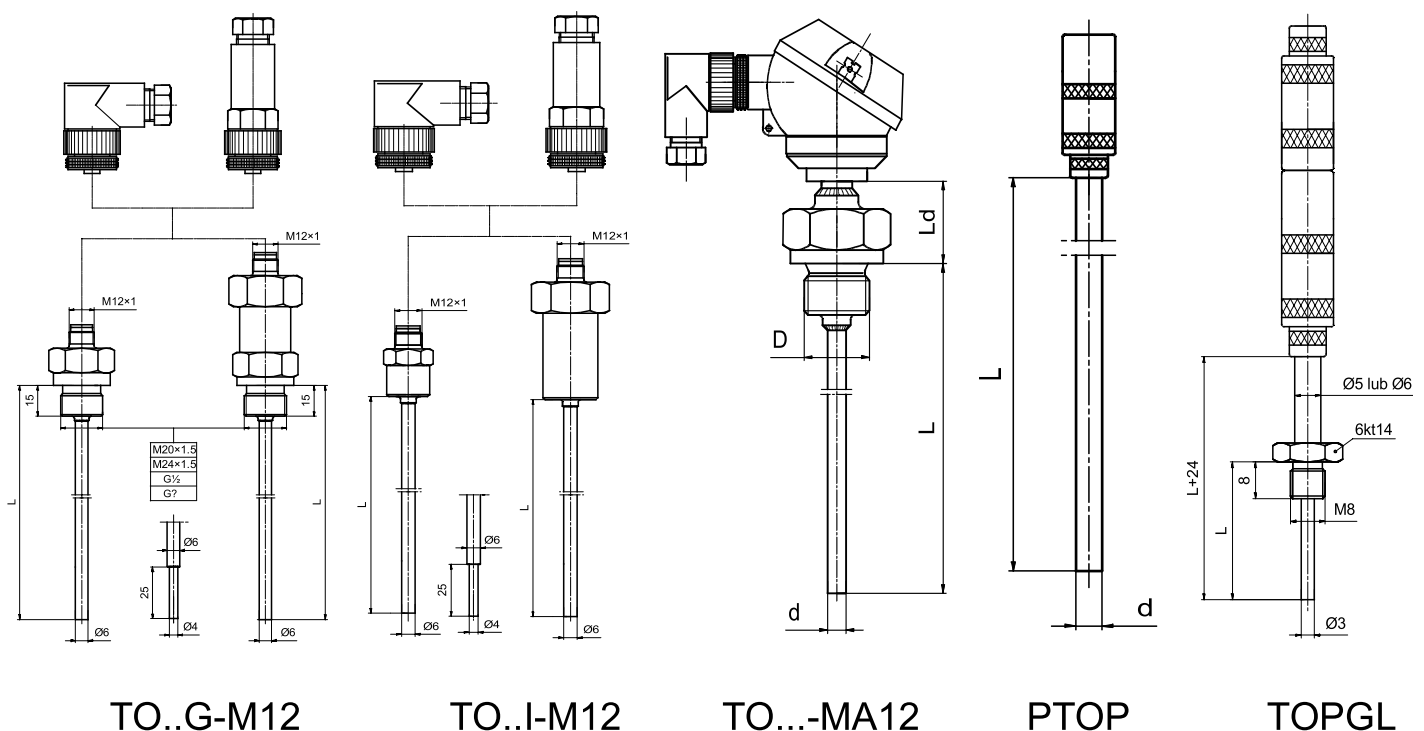

Sensor type	Thermowell material	Temperature range	Installation type (standard)	Thermowell diameter
TO...GSP-1	1.4541	-50÷150°C	Threaded welded connector	ø4/6 or ø6
TO... - M12	1.4541	-50÷250°C	UG-3 or threaded welded connector M8 to M20	ø4/6 or ø6
TOP-MA12	1.4541	-200÷400°C	UG-3 or threaded or flanged connector	ø6÷10
PTOP-BTL	1.4571	-50÷400°C	UG-3	ø3, ø6
TOPGL-1082	1.4541	-50÷200°C	Threaded welded connector M8	ø3

Specification:

Resistor type:.....1 or 2x Pt100, 500, 1000; class A, B acc. to PN-EN 60751
1 x Ni100, 1000 acc. to DIN 43760

Connection type:.....2, 3, 4-wire

Max. temperature range:-200÷400°C for Pt
-50÷250°C for Ni

Connectors parameters:

Parameters		GSP	M12	LEMO
Operating temperature		-40÷125°C	-25÷90°C	-50÷250°C
Number of pins		4	4	2 or 4
Tightness acc. to PN-EN 60529		IP65	IP67	IP50
Max. cable diameter/ crosssection	Cable gland PG7**	–	4÷6/0,75	size 0 - 6 / 0,25* size 1 - 8 / 0,34* size 2 - 10 / 0,5* size 3 - 13 / 1,0*
	Cable gland PG9**	4,5÷7 / 1,5	6÷8/0,75	
	Cable gland G1/2**	6÷13 / 1,5	–	

*applies to 4-pin connectors; for 2-pin connectors cross-section is from 0,34 to 1,5

** applies only to GSP and M12

2. Instalattion.

Temperature sensors shall be mounted in place of measurement in compliance with the recommended way of installation; if possible, in places enabling control of operating and replacement in case of damage. The accuracy of temperature measurement depends on the correct way of sensor installation. One shall remember that the temperature sensor transmits signals dependent on the temperature of the sensing element. Since the part of the temperature sensor is beyond the place of measurement, in ambient temperature, and

the thermowell is a good thermal conductor, it results in change of temperature distribution in the place of measurement through constant heat removal to the surrounding. The bigger the ratio of length of this part of sensor which is in ambient temperature to the length of the whole sensor, and the bigger the difference between the ambient temperature and temperature in place of measurement, the bigger are the changes influencing the accuracy of measurement.

In the event of very accurate temperature measurements, the requirements given below shall be followed during the sensor installation:

- parts of sensor thermowell beyond the place of measurement shall be thermally insulated
- connecting wires, especially in case of long distances, shall be arranged in a way preventing exposure to high temperature variations. In case of RTD sensor 3-wire connection is recommended.
- longer (deeply immersed) sensors shall be used for obtaining a better ratio of thermowell length in ambient temperature to total length
- pipelines with smaller cross-section shall be used in place of measurement for the purpose of increasing the flow velocity and intensification of heat transfer in pipelines with low flow rate (esp. gaseous).

3. Cable connection and arrangement.

Copper wire with the maximum cross-section that can be connected with the adequate plug shall be used for connection between the temperature sensor and measuring device, in accordance with standards referring to low voltage installation. Wire joining shall be avoided. If necessary, solder joints are recommended. All instructions provided in the Operation Manual of the device that will work with the temperature sensors shall be observed.

Wires shall be connected with a plug acc. to the drawings below which show the way of connecting resistor and transmitter with pins of the particular plug:

- GSP

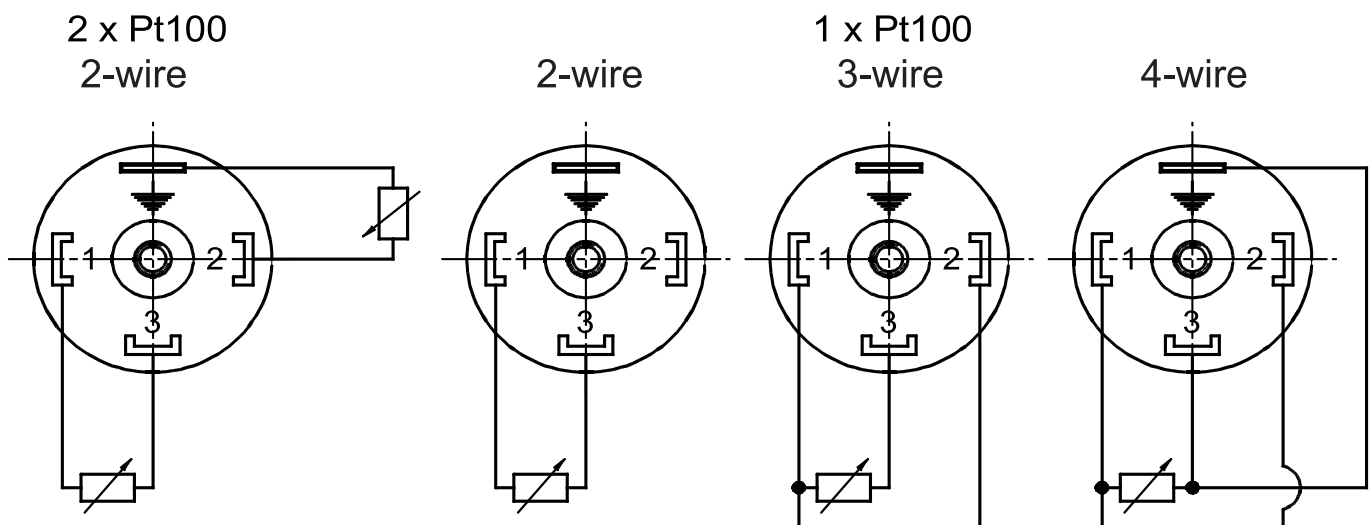

• M12

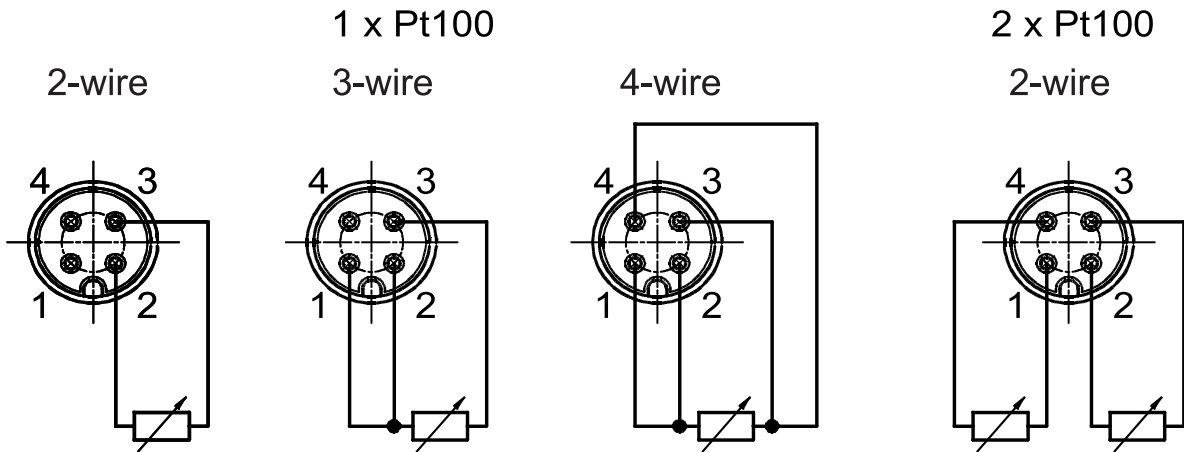

• LEMO

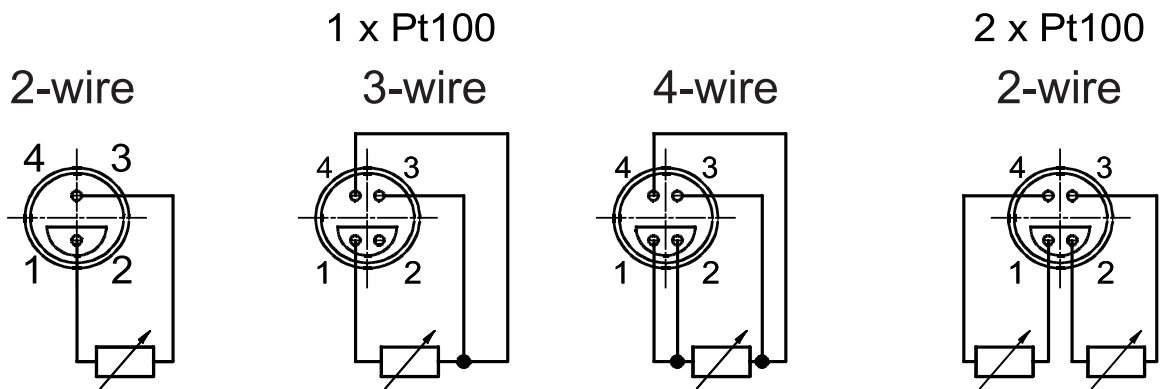

• transmitter type RT-02

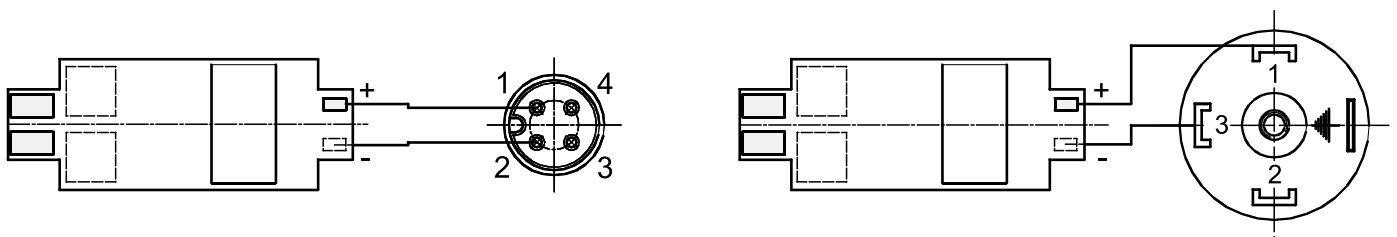

• transmitter LTT03J (in MA connection head)

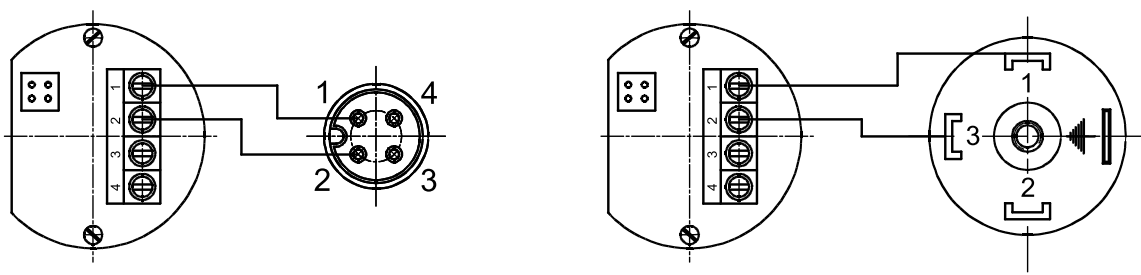

Single sensors without transmitters can be mounted with peripheral devices with the use of 2-, 3- or 4-wire configuration – details are provided below; double sensors: only 2-wire configuration; similarly sensors with transmitter (only single):

- 2-wire connection line

Suitable for applications when a high accuracy is not required. Wire resistance $R_1 + R_2$ introduces an error $2,6^{\circ}\text{C}$ for Pt100 per one Ω of a wire; about $0,26^{\circ}\text{C}$ for Pt 1000 per one Ω of a wire.

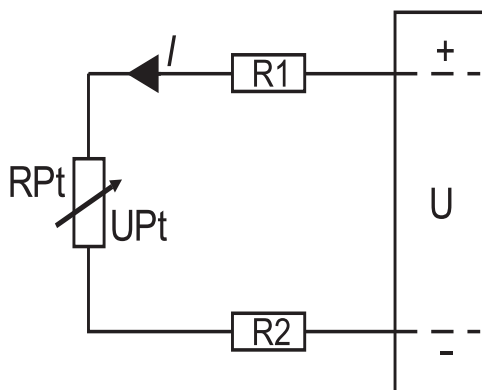

- 3-wire connection line

The most popular in industry because of the automatic compensation of resistance changes depending on the temperature and the compensation of wire resistance (two red, one white).

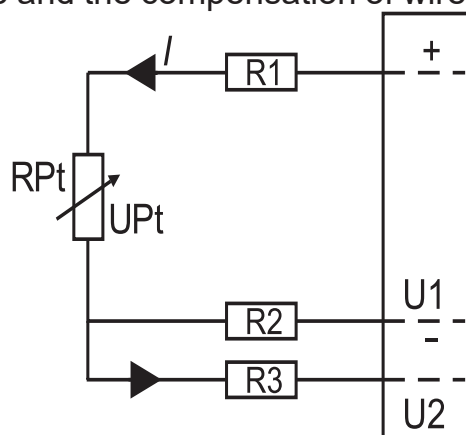

Connecting wires must have identical resistance $R_1=R_2=R_3$. The table below provides examples of errors for 3-wire connection for Pt100 and Pt1000 for difference of wire resistance 0.1Ω and 1Ω .

	Difference in the resistance of wires	
	0.1Ω	1Ω
Pt100	0.26°C	2.6°C
Pt1000	0.03°C	0.26°C

For practical reasons resistance of single line of RTD input circuit shall not exceed 11Ω .

4-wire connection line $R_1=R_2=R_3=R_4=R$

This connection is used in case of very high accuracy, because it eliminates completely the influence of wire resistance.

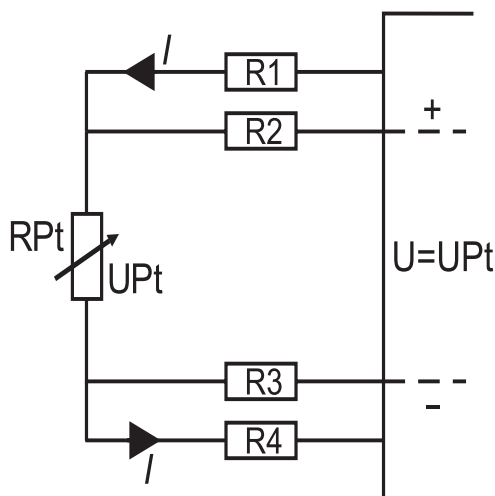

For practical reasons resistance of single line of rtd input circuit shall not exceed 11Ω.

4. Packing, storing and transportation instructions.

For the purpose of transportation temperature sensors should be properly packed (as multipacks and/or individual packages) in order to avoid any damage. They should be stored indoor in their original packages; the indoor air must be free of vapours and/or aggressive substances, the indoor air must range from +5°C to 50°C, and the relative humidity must not exceed 85 %. Whilst being transported, the sensors must be protected against shifting inside the packaging. Temperature sensors can be transported by air, by sea and road providing that the direct influence of atmospheric agents is eliminated. Transport conditions acc. to PN-81/M-42009.

5. Warranty.

- The Manufacturer provides the original purchaser of the sensor (sensors) with a twelve (12) month warranty and necessary service; for this period, the Manufacturer guarantees the uninterrupted and error free functioning of sensors;
- The twelve (12) month warranty begins on the day of purchase;
- The warranty voids in the case of any changes in and repairs of the instrument;
- This warranty does not cover damages resulting from improper transportation, nor defects and errors caused by bad handling or misuse which does not comply with the provisions as set forth in this Operation Manual.