

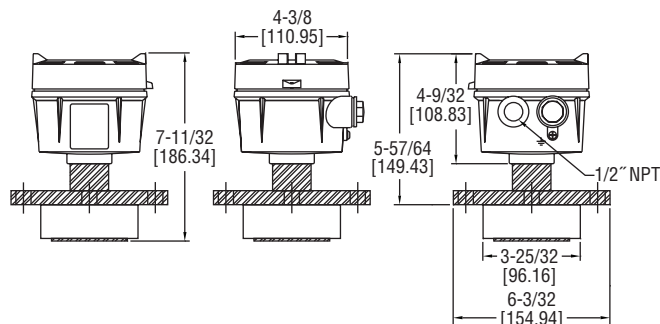

Model FCLS Flush Capacitance Level Switch

Specifications - Installation and Operating Instructions



The **Model FCLS Flush Capacitance Level Switch** is ideal for level measurement of liquids and bulk solids to trigger an alarm or close a filler inlet. No probe design allows for installation where space is constrained or where material flow or material build up would damage a probe. With no moving parts, this level switch assures no jams, no wear, nothing to break, and no maintenance. Comes standard with IP65 housing with a maximum pressure limit of 285 psi (19.7 bar).

Coarse Calibration

To calibrate the coarse adjustment of the FCLS, the following steps should be followed:

1. Set the sensitivity adjustment to the H position.
2. Using a screw driver, adjust the coarse sensitivity until the indicator lamp turns on.
3. Check to see if indicator lamp turns on when adjusting the sensitivity knob. If not, repeat procedure.

Sensitivity Adjustment

To adjust the sensitivity of the FCLS, the following procedure should be followed:

1. When the material is detected by the level switch, the indicator lamp will illuminate. Otherwise, it will remain off.
2. While the level switch is detecting the material, adjust the sensitivity knob until the indicator lamp turns off.
3. Set the sensitivity adjustment knob in the middle position between where the indicator lamp turns on and where it turns off.

SPECIFICATIONS

Service: Liquids, powder, and bulk materials compatible with wetted materials.

Wetted Materials: 304 SS.

Insulated Materials: PTFE.

Temperature Limits:

Ambient: -4 to 140°F (-20 to 60°C);

Process: -4 to 176°F (-20 to 80°C).

Pressure Limit: 285 psi (19.7 bar).

Power Requirements: 110 or 220 VAC.

Power Consumption: 2 W.

Enclosure: Aluminum, painted.

Enclosure Rating: IP65.

Switch Type: SPDT.

Electrical Rating: 3 A @ 250 VAC.

Electrical Connections: Screw terminals.

Conduit Connection: 2 x 1/2" female NPT.

Process Connection: 2.5" - x 5 kg/cm² JIS flange.

Mounting Orientation: Side mount.

Fail Safe: Selectable fail high or fail low.

Adjustable Sensitivity: 1 to 20 pF.

Time Delay: 0 to 6 seconds.

Weight: 7.1 lb (3.2 kg).

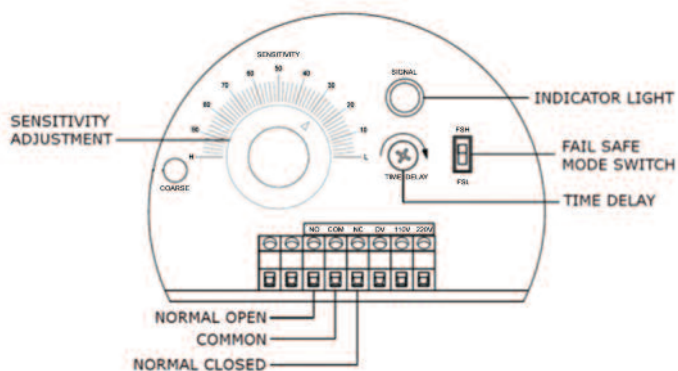

Figure A

Time Delay Selection

The time delay is the programmed time between when the surface senses the presence or absence of materials and when the relay changes state. A time delay is good for applications that could have false or rapid pulsing of level indications from sloshing or agitated material. Choose a delay setting appropriate for the specific application. The default delay setting is set at 0 seconds. The maximum time delay is 6 seconds. To increase the delay time from zero, turn the TIME DELAY potentiometer clockwise (see Fig. A).

MOUNTING

The FCLS should be horizontally mounted. The mounting wall thickness should not exceed 0.98" (25 mm).

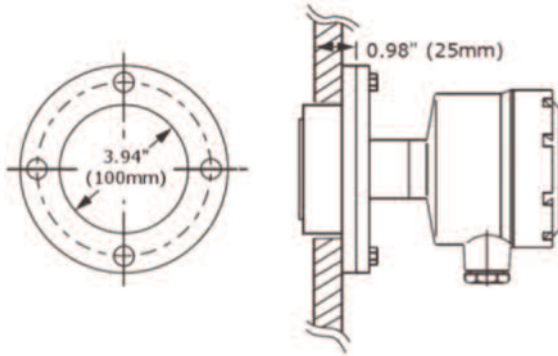

FAIL SAFE SELECTION

FSH Mode

Fail-Safe High means that the relay will be energized when the sensing surface is uncovered by the material (SIGNAL LED is on) and will de-energize with the sensing surface is covered (SIGNAL LED is off). In this mode, a power failure will cause the relay to de-energize like the surface is covered.

FSL Mode

Fail-Safe Low means that the relay will be de-energized when the sensing surface is uncovered (SIGNAL LED is off) and will energize with the probe is covered (SIGNAL LED is on). In this mode, a power failure will cause the relay to de-energize like the surface is uncovered.

MAINTENANCE/REPAIR

Upon final installation of the Model FCLS no routine maintenance is required. The Model FCLS is not field serviceable and should be returned if repair is needed. Field repair should not be attempted and may void warranty.

WARRANTY/RETURN

Refer to "Terms and Conditions of Sales" in our catalog and on our website. Contact customer service to receive a Return Goods Authorization number before shipping the product back for repair. Be sure to include a brief description of the problem plus any additional application notes.